

# Co Channel Interference Rejection of OFDM signals using frost Beamforming Technique

Hemant Kumar Vijayvergia<sup>1</sup>, Garima Saini<sup>2</sup>

Electronics & Communication Engineering Department<sup>1,2</sup> Govt. Mahila Engineering College, Ajmer <sup>1</sup>NITTTR Chandigarh<sup>2</sup>

Email:hemantv19@gmail.com<sup>1</sup>, garimasaini\_18@rediffmail.com<sup>2</sup>

**Abstract-**Beamforming is a signal processing method intended to perform a spatial filtering in which an array of receiving antennas is employed to achieve full signal reception in a specified path by estimating the signal coming from a desired direction (in the presence of noise) while signals of the similar frequency from other directions are rejected. This is achieved by varying the weights of each of the receiving sensors (antennas) used in the array. It basically uses an idea that, though the signals originating from different transmitters inhabit the identical frequency channel, they still arrive from various directions. This spatial separation is oppressed to separate the desired signal from the interfering signals. For determining the optimum weights, iteratively computing methods using complex algorithms based upon different criteria are used. The purpose of this study is to analyze Frost Beamforming technique on OFDM signals. A receiver system model containing linear array of receiving sensors with and without frost beamforming signal processing is demonstrated. The co channel interference noise reduction is derived as a function of the direction of arrival of signal and direction of CCI noise reception at linear array of sensor. The frequency response of received OFDM signal is observed and its effects on received spectrum and throughput are analyzed in all the cases.

**Index Terms-** Co channel Interference (CCI)<sup>1</sup>; Orthogon Frequency Division Multiplexing<sup>2</sup>; Beamforming Technique<sup>3</sup>; Noise Rejection<sup>4</sup>.

## 1. INTRODUCTION

Orthogonal Frequency Division Multiplexing (OFDM) technique is a simple building block for various current modulation schemes including; 802.11 WLAN, 802.16 WiMAX, and 3GPP LTE. OFDM is a digital multi-carrier modulation scheme that covers the concept of single subcarrier modulation with multiple subcarriers within the same single channel. Instead of transmitting a high rate stream of data with a single subcarrier, OFDM makes application of a huge number of closely spaced orthogonal subcarriers that are transferred in parallel. Every subcarrier is modulated with a conventional digital modulation scheme (such as QPSK, 16QAM, etc.) at small symbol rate. However, the grouping of many subcarriers enables data rates similar to orthodox single-carrier modulation schemes within equivalent bandwidths. OFDM procedure increases the symbol length by distributing the entire channel into many slender sub channels and communicating data in parallel [1, 2].

A key problem linked with orthogonal frequency division multiplexing is its huge peak-to-average power ratio (PAPR). This PAPR lowers the system performance by introducing nonlinearity in the devices such as power amplifiers (PAs). In order to moderate nonlinear distortion, direct high power amplifiers and analogue to digital converters with a large dynamic array are required, but such power amplifiers are inefficient. Sub-carriers in an OFDM system are overlapping to maximize spectral proficiency. Normally, overlapping contiguous channels

can affect with each another. However, sub-carriers in an OFDM system are precisely orthogonal to each another.

Thus, they can overlap without interfering. As a result, OFDM systems are capable of maximizing spectral efficiency lacking causing adjacent channel interference [3]. Beamforming is completed by phasing the feed for each element of an array so that signals received or transferred from all features will be in phase in an individual direction. The phases (the inter element phase) and usually amplitudes are adjusted to optimize the received signal.

## 2. OFDM SYSTEM MODEL

Orthogonal Frequency Division Multiplexing is a frequency division multiplexing (FDM) scheme utilized as a digital multicarrier modulation system. A huge number of closely spread out orthogonal sub – carriers is used to carry data. Figure 1 shows a block diagram of an OFDM system [4].

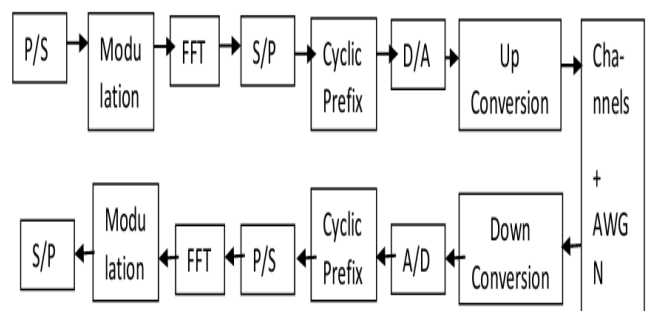

Fig. 1: OFDM Block Diagram

OFDM systems are applied using amalgamation of fast Fourier Transform (FFT) and Inverse fast Fourier Transform (IFFT) chunks that are mathematically

equivalent versions of the DFT and IDFT, respectively, but easily implemented. An OFDM system treats the source symbols (e.g., the BPSK, QPSK or QAM symbols that would be present in a single carrier system) at the transmitter in the frequency-domain [5]. These symbols are used as the inputs to an IFFT block that carries the signal into the time domain. The IFFT takes in N symbols at a time where N is the number of Subcarriers in the system.

Every N input symbols has a symbol period of T seconds. Recall that the basic functions for an IFFT are N orthogonal sinusoids. Each and every sinusoids have a specific frequency and the least frequency is DC. Every input symbol perform like a complex weight for the matching sinusoidal fundamental function. Since the input symbols are difficult. Amplitude and phase values of the sinusoid signal for all sub carrier are determined by these symbols [6].

The IFFT output is the summation of all N sinusoids. Thus, the IFFT block delivers a modest way to temper data onto N orthogonal subcarriers. The block of N output examples from the IFFT make up a single OFDM symbol. Later on further processing in the time-domain that results from the IFFT is transferred across the channel. Figure 2 shows the block diagram of OFDM transmitter[7].

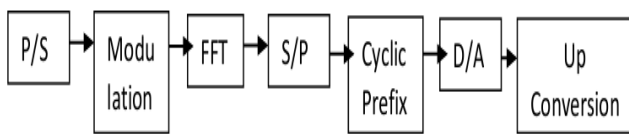

Fig. 2: OFDM Transmitter Blocks

At the receiver end, FFT converts the signal into the frequency domain. These are the original signals ideally those were sent to the IFFT at the transmitter. When designed in the complex plane, the FFT output samples form a group. Time domain signal shows no fixed shape when it is plotted in complex plane. So, it is good idea to have an frequency domain signal[8-11]. OFDM receiver is shown in Figure 3.

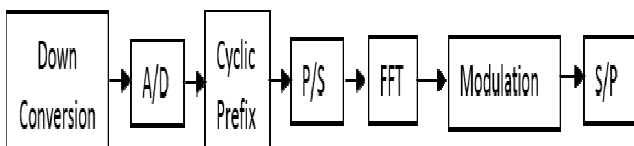

Fig. 3: OFDM Receiver Blocks

### 3. BEAMFORMING TECHNIQUES

Beamforming is an advanced signal processing method which, when engaged along with an array of transmitters or receivers will be proficient of monitoring the 'directionality of' or 'sensitivity to' a particular radiation shape. This method creates the radiation pattern of the

antenna array by adding the phases of the signals in the desired direction and by nullifying the pattern in the several directions. The entombement phase usually adjusts the amplitudes to elevate the received signal [12].

Microphone arrays based on the minimum variance distortion less response (MVDR) beamformer are among the most popular for speech enhancement applications. The original MVDR is extremely sensitive to source location and microphone gains. Former research has made MVDR practical by successfully increasing the robustness of MVDR to source site, and MVDR-based microphone arrays are commercially vacant. Nevertheless, MVDR performance is quiet weak in cases where microphone gain variations are unreasonably large, e.g., for rounded arrays of directional microphones [14].

Linear constraint minimum variance (LCMV) depends on the received weight vector of the desired signal [14, 15]. Frost's beamformer as shown in Figure 4(a) comprises of an array with K sensors, where every sensor is followed by a transversal filter with J weights. The number of weights is equal for all transversal filters. The total of the filter outputs is the beam former output. Weights are updated by Frost's constrained least mean square (CLMS) algorithm which minimizes the mean square error of the output signal while satisfying a constraint [16]. In order the input signal  $s(t)$  to be passed without any distortion, the impulse response of the whole system must be same to the unit impulse. This response signifies the constraint for the weights of all filters. The whole system can be replaced by one transversal FIR filter for the signals  $s(t)$ . The replacement is shown in Figure 4(b), where  $f_1, f_2, \dots, f_j$  is the impulse response for the signal. Constraint equations can be written also in matrix form as:

$$W \begin{bmatrix} 1 \\ \vdots \\ 1 \end{bmatrix} = \begin{bmatrix} f_1 \\ \vdots \\ f_j \end{bmatrix} \quad (1)$$

Where, W stands for weight matrix with actual elements

$$\begin{bmatrix} w_1 & \dots & w_k \\ \vdots & \ddots & \vdots \\ w_{jk-k+1} & \dots & w_{jk} \end{bmatrix} \quad (2)$$

To discuss the Frost's beam former behavior in detail, let us define some relationships needed. The digitized input noisy signals  $x_i[n]$ .

Where,  $i = 1, 2, \dots, JK$  are formed by components of both clean signals  $(t)$  and noise  $n(t)$ .

The vector  $\tilde{x}[n]$  represents noisy signals on taps, the vector  $w$  involves weights value, and the vector  $F$  represents the constrained impulse response and the matrix  $C$  will be used in constraint formulation.

$$\begin{aligned} \tilde{x}^T[n] &= [x_1[n] \ x_2[n] \ \dots \ x_{jk}[n] ], \\ w^T &= [w_1 \ w_2 \ \dots \ w_{jk}], \\ FT &= [f_1 f_2 \ \dots \ f_j], \\ C &= [c_1 c_2 \ \dots \ c_j]. \end{aligned} \quad (3)$$

Elements  $C_i$  represent the column vectors of length  $jk$  with  $(i-1)K$  zeroes followed by  $K$  ones and  $(j-i)K$  zeroes

$$c_i^T = \underbrace{[0 \ 0 \ \dots \ 0 \ 1 \ 1 \ \dots \ 1 \ 0 \ 0 \ \dots \ 0]}_{(i-1)K \text{ zeroes} \quad k \text{ ones} \quad (j-i)k \text{ zeroes}} \quad (4)$$

Now find out the optimum weight vector for a stationary signal  $w_{opt}$  (Wiener solution) can be formulated.

The weight vector minimizing  $E[y_2(n)] = w_{opt}^T \tilde{x}(n) \tilde{x}(n)^T w = w^T R_{xx} w$  and satisfying the constraint  $C^T w = F$  have to be found.  $R_{xx}$  stands for the autocorrelation matrix [16].

$$w_{opt} = R_{xx}^{-1} C (C^T R_{xx}^{-1} C)^{-1} F \quad (5)$$

and the adaptive CLMS algorithm

$$\begin{aligned} w[0] &= f, \\ w[n+1] &= P(w[n] - \mu y[n] \tilde{x}[n]) + f. \end{aligned} \quad (6)$$

The vector  $f$  and the projection matrix  $P$  are defined as

$$\begin{aligned} f &= C (C^T C)^{-1} F, \\ P &= E - C (C^T C)^{-1} C^T. \end{aligned} \quad (7)$$

Positive scalar  $\mu$  is a step-size parameter. The selection of  $\mu$  is the trade-off between the convergence time and the miss adjustment of weights from Wiener solution. An easily computable upper bound for  $\mu$  is given by  $\mu < 2/(3E[\tilde{x}^T \tilde{x}])$ .

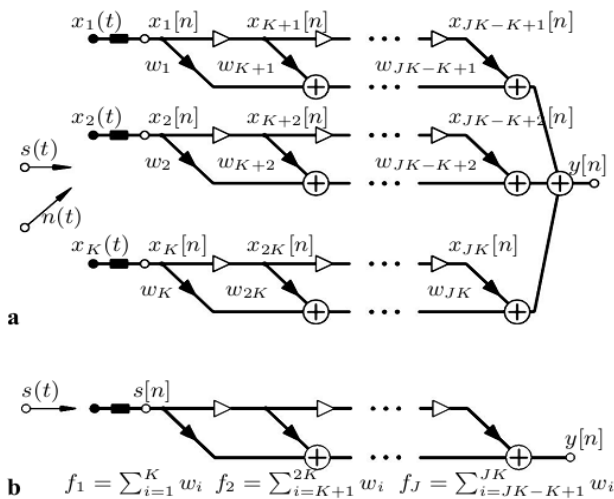

Fig. 4: (a) Frost's beam former structure, (b) Frost's beam former from  $s(t)$  view - constraint formulation[3]

The convergence performance and the choice of  $\mu$  is deeply discussed in [17].

The alternative form of "Eq. (6)" for the implementation is

$$w_i[n+1] = w_i[n] - \mu y[n] x_i[n] - \frac{1}{k} \sum_{\left\lfloor \frac{i}{k} \right\rfloor k-1}^{\left\lfloor \frac{i}{k} \right\rfloor k+1} w_i[n] - \mu y[n] x_i[n] + \left[ \left( \left\lfloor \frac{i}{k} \right\rfloor + 1 \right) / k \right] \quad (8)$$

The signal vector of array components shown in "Eq. 9" [17].

$$A(\theta) = e^{j 2\pi / \lambda (\sin \theta) d} \quad (9)$$

Where,  $\theta$  is angle of direction of appearance of signal with the axis of array,  $M$  is no of receiver antenna in linear array with  $d$  spacing between the antennas as shown in Fig. 5.

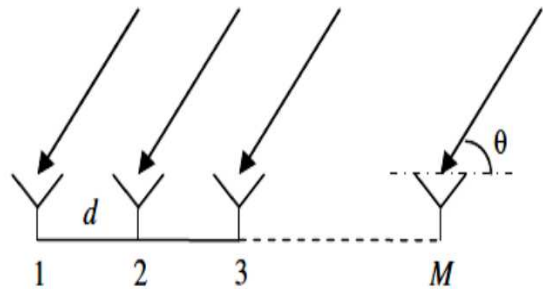

Fig. 5: Beamforming linear array of receivers

#### 4. SIMULATION AND RESULTS

Table 1. Considered parameters for simulation

No of Receivers Sensors	4
Initial Sensor Weights	[0.2 0.4 0.6 0.8]
Sensors Spacing	0.5 meters
Lambda	0.0759
No. of IFFT samples	274

A sample OFDM signal is generated through random values, which is showing in figure 6(a). A sample of noise signal is taken which is shown in figure 6(b). This noise signal is introduced in sample OFDM signal. Main purpose of this study is to filter out this noise from the received signal at receiving end.

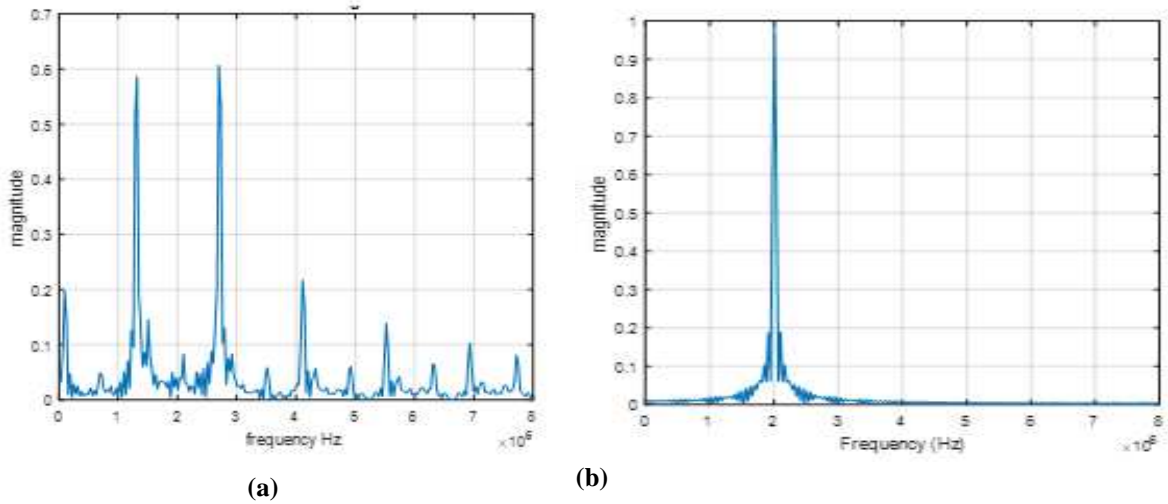

Fig.: 6 (a) generated OFDM signalspectrum (b) Noise Signal spectrum

Figure 7(a) is showing noisy signal which is received at the receiving end. Figure 7(b) - (j) depicted various graphs plotted bywarring angle of direction

of arrival of signal array and angle of co-channel interference as given in table 2.

Table 2.Figures respect to beamformed signal with angle of direction of arrival of signal and angle of co-channel interference.

Figure No.	Angle of direction of arrival of signal (degree)	Angle of co-channel interference in (degree)
Figure 7 (b)	0	0
Figure 7 (c)	0	30
Figure 7 (d)	0	270
Figure 7 (e)	45	90
Figure 7 (f)	45	120
Figure 7 (g)	30	150
Figure 7 (h)	30	270
Figure 7 (i)	45	270
Figure 7 (j)	60	300

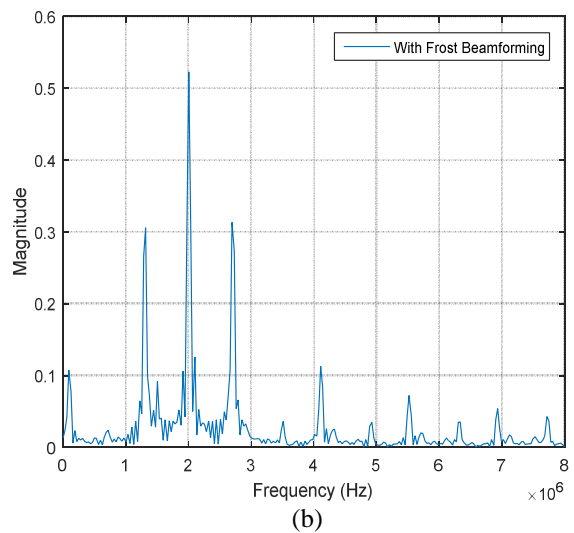
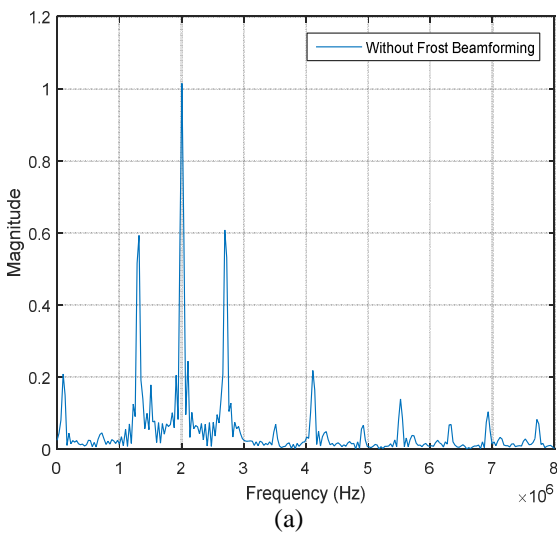

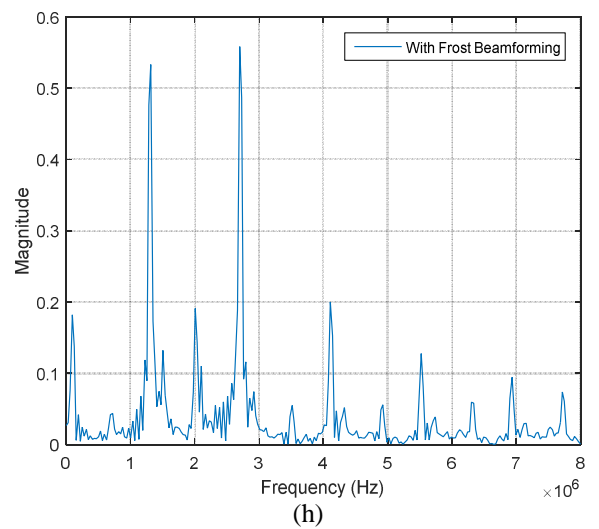
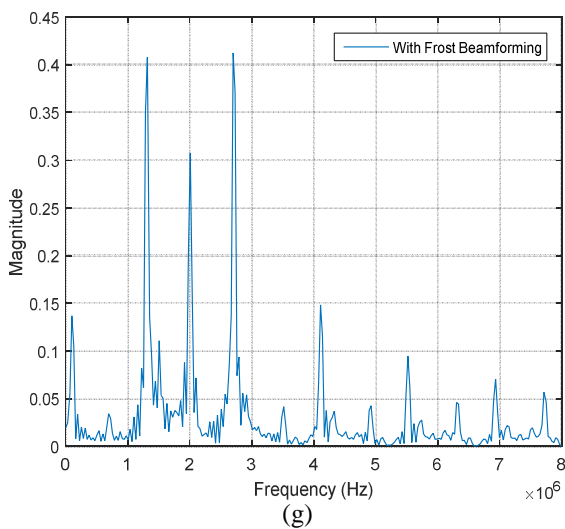
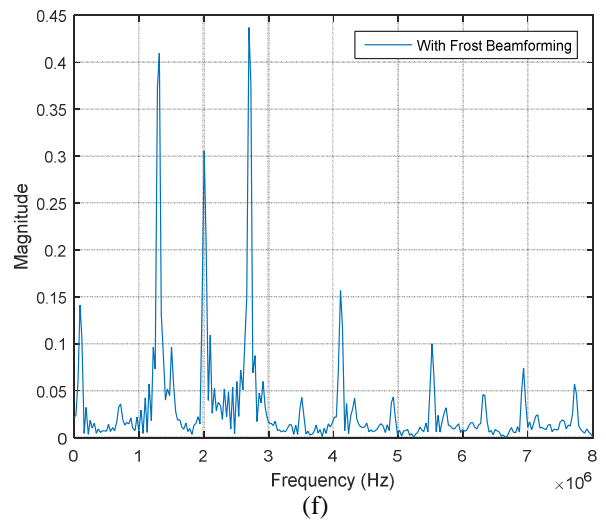
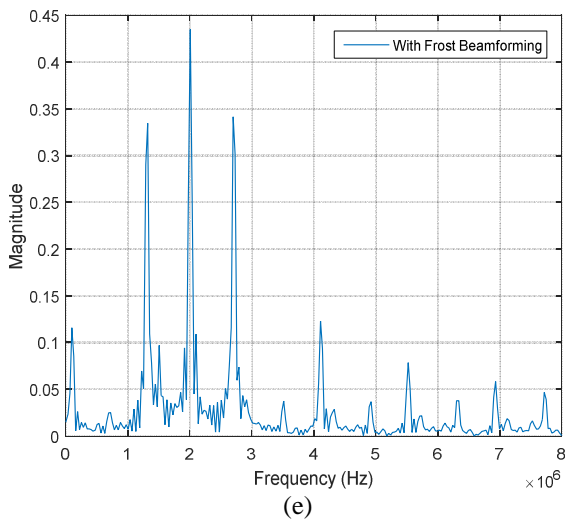
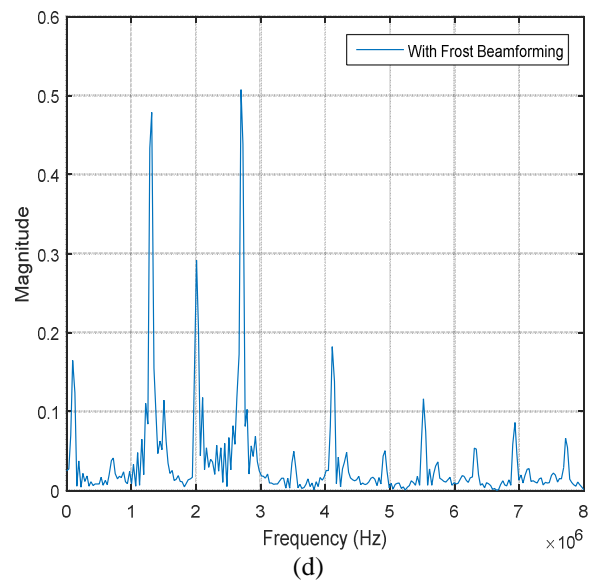
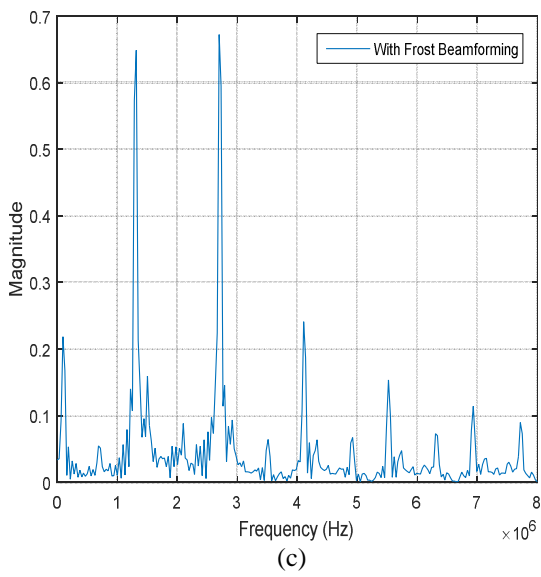

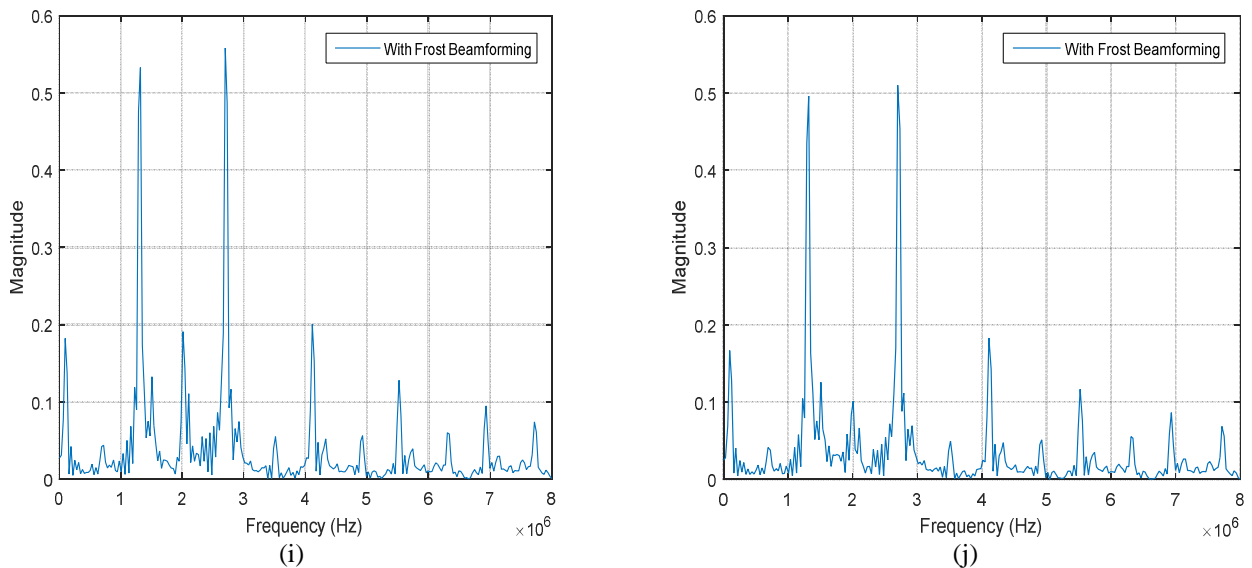

Fig. 7 (a) received signal at the receiving end with noise and

(b)-(j) is showing beamformed signal with respect to angle of direction of arrival of signal and angle of co-channel interference according to table 2

Average bit error rate (through-put) for normal linear reception array is observed to be 0.4964 and average bit error rate for frost beamformed array is observed to be 0.0036.

## 5. CONCLUSION

Combination of linear sensor arrays and OFDM signal and correlation between direction of signal reception and its signal strength is performed throughout the study. Frequency response was derived as functions of the direction of appearance of the signal and the signal processing was performed using frost Beamforming technique. All possible symmetry's were shown using this configuration concept. When the noise uncorrelated among sensors and samples dominates to the filter remains in its initial state. Thus adaptation procedure takes no outcome. From the graphs, it is observed that for the angle of direction of arrival of signal  $0^0$  and angle of co-channel interference  $30^0$ , filtered signal is most similar to original transmitted signal.

## REFERENCES

- [1] Mignone and A. Morello (1996) "CD3-OFDM: A novel demodulation scheme for fixed and mobile receivers," IEEE Transaction on Communication, vol. 44, pp. 1144–1151.
- [2] Ye Li and R. N. Sollenberger (1999) "Adaptive antenna arrays for OFDM systems with cochannel interference," IEEE Transaction on Communication, vol. 47, pp. 217–229.
- [3] Muquet, Z. Wang, G. B. Giannakis, M. de Courville and P. Duhamel (2002) "Cyclic prefixing or zero padding for wireless multicarrier transmissions," IEEE Transaction on Communication, vol. 50, pp. 2136–2148.
- [4] H. Rohling and R. Grunheid (1997) "Performance comparison of different multiple access schemes for the downlink of an OFDM communication system," in Proceeding of IEEE Vehicular Technology Conference, pp. 1365–1369.
- [5] B. Widrow, K. M. duvall, R. P. Gooch, W. C. Neuman (1982) "Signal cancelation phenomena in adaptive antennas: causes and cures," IEEE Transactions on Antennas and Propagation, vol. AP-30, no. 3, pp. 469-478.
- [6] S. WERNER, J. APOLINARIO, T. Laakso (1998) "Multiple-antenna CDMA mobile reception using constrained normalized adaptive algorithms" In Proceedings SBT/IEEE International Telecommunications Symposium ITS'98, Sao Paulo (Brazil), pp. 354-358.
- [7] Y. Bahceci and T. M. Duman (2002) "Combined Turbo Coding and Unitary Space-Time Modulation," IEEE Transaction on Communication, Vol. 50, No. 8, pp. 1244–1249.
- [8] Zhao hongwei, LianBaowang and Feng Juan (2011) "Adaptive Beamforming Algorithm for Interference Suppression in Gnss Receivers" International Journal of Computer Science & Information Technology (IJCSIT) Vol 3, No 5.
- [9] Lal C. Godara (1997) "Application of Antenna Arrays to Mobile Communications, Part II: beam-forming and direction-of-arrival considerations", Proceeding of the IEEE, Vol. 85, No. 8, pp. 1195- 1234.
- [10] Susmita Das (2009) "Smart Antenna Design for Wireless Communication using Adaptive Beam-forming Approach".

- [11] Bow-Tie (2007) "Antenna for GSM/CDMA and 3G/WLAN", Microwave, antenna, propagation and EMC Technologies for International symposium on Wireless Communication, pp. 504 – 507.
- [12] Dahrouj H., Yu W. (2010) "Coordinated Beamforming for the Multicell Multi-Antenna Wireless System". IEEE Transactions on Wireless Communications, vol. 9, no. 5.
- [13] Demba E. Ba, DineiFlorêncio and Cha Zhang, "Enhanced MVDR Beamforming for Arrays of Directional Microphones"
- [14] C. Zhang, Z. Zhang, and D. Florencio (2007) "Maximum Likelihood sound source localization for multiple directional microphones," ICASSP, pp. 125–128.
- [15] Balasem. S.S and S.K.Tiong, S. P. Koh (2012) "Beamforming Algorithms Technique by Using MVDR and LCMV" World Applied Programming, Vol (2), No (5).
- [16] FROST, O. L. (1972) An algorithm for linearly constrained adaptive array processing. In Proceedings of IEEE, vol. 60, no. 8, p. 926-934.
- [17] Zhao hongwei, LianBaowang and Feng Juan (2011) "Adaptive Beamforming Algorithm for Interference Suppression in Gnss Receivers" , International Journal of Computer Science & Information Technology (IJCSIT) Vol 3, No 5.